

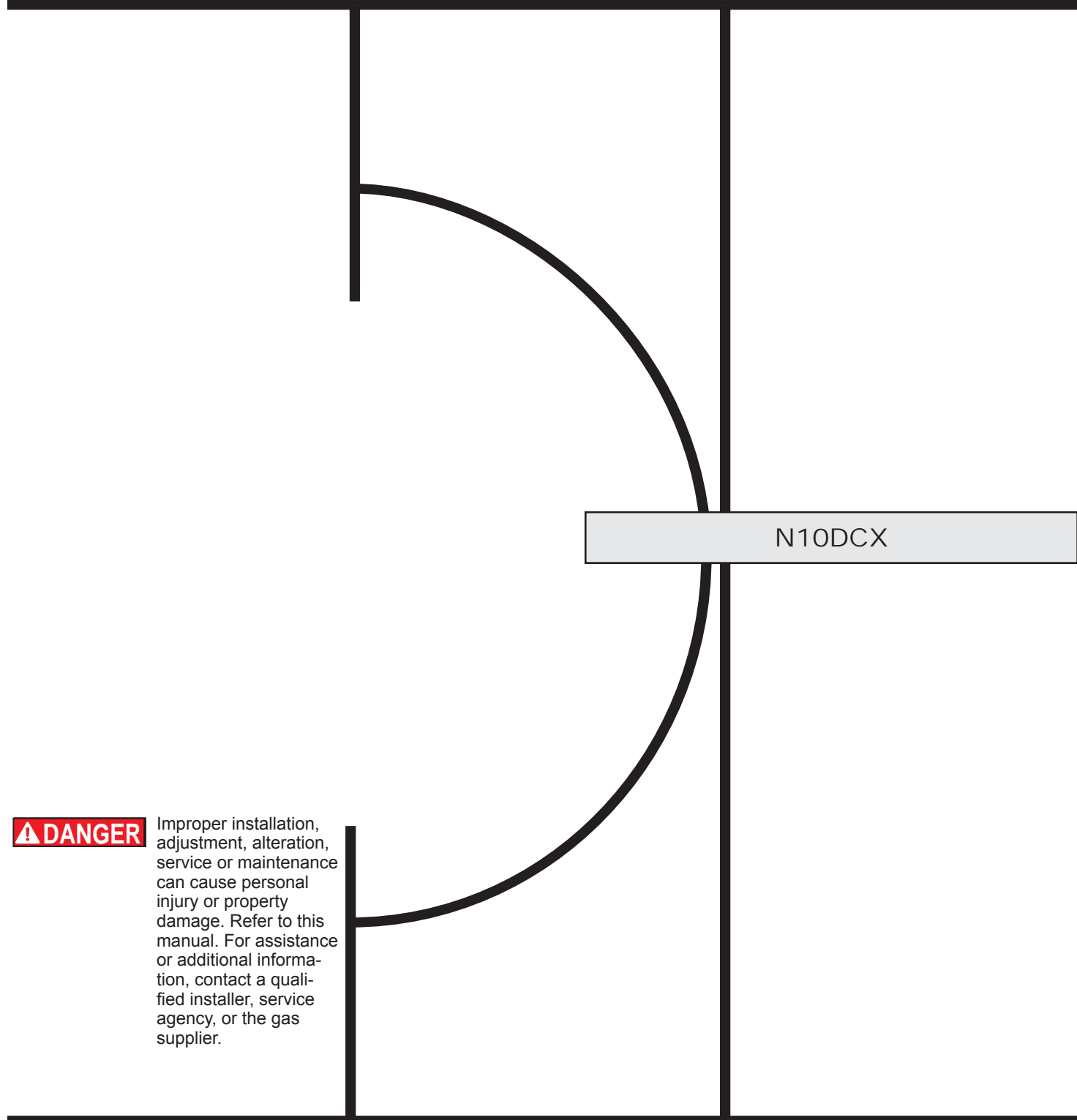

# Service Manual Compressor Refrigerators

English



**⚠ DANGER**

Improper installation, adjustment, alteration, service or maintenance can cause personal injury or property damage. Refer to this manual. For assistance or additional information, contact a qualified installer, service agency, or the gas supplier.

**Questions? 1-800-543-1219**

# CONTENTS

<b>SAFETY</b> .....	<b>2</b>
<b>INTRODUCTION</b> .....	<b>3</b>
About this Manual .....	3
Certification and Code Requirements .....	3
About Installation .....	3
Replacement Parts .....	3
Technical Assistance .....	3
<b>SPECIFICATIONS</b> .....	<b>4</b>
Refrigerator Model Number .....	4
Exploded Views .....	5
<b>GENERAL INFORMATION</b> .....	<b>7</b>
Installation .....	7
Ventilation .....	7
Overview .....	7
12 Volts DC Electrical Connection .....	7
Polarity .....	7
Parallel Battery .....	7
<b>DIAGNOSTICS</b> .....	<b>8</b>
Diagnostic Pre-Checks .....	8
Self-Test Diagnostics .....	9
Table of LED References .....	9
Conducting the LED Evaluation .....	9
Prepare to Connect the LED .....	9
Connect the LED .....	9
Self-Test Diagnostic Chart .....	10
Diagnostic Symptom Chart .....	10
Electronic Controls Fault Code Chart .....	10
<b>TROUBLESHOOTING</b> .....	<b>11</b>
Troubleshoot Compressor Control Module .....	11
Test A, Battery Protection Cut-Out .....	11
Test B, Fan Over Current Cut-Out .....	13
Test C, Motor Start Error .....	14
Test D, Minimum Motor Speed Error .....	15
Test E, Thermal Cut-Out of Electronic Unit .....	16
Troubleshoot Symptoms .....	17
Test F, Not Cooling, Not Turning On .....	17
Test G, Refrigerator Gets Too Cold .....	19
Test H, Refrigerator Builds Frost Inside .....	20
Test I, Runs But Does Not Cool Properly .....	21
Test J, Will Not Run On DC Power .....	22
Test K, Voltage Within Cutout Range but Refrigerator Cuts Out .....	23
Troubleshoot Electronic Controls Fault Codes .....	24
Fault Code - "E1" .....	24
Fault Code - "E2" .....	25
Fault Code - "E3" .....	26
Fault Code - "E4" .....	26
<b>WIRING DIAGRAM</b> .....	<b>27</b>
<b>REFRIGERATOR ENCLOSURE</b> .....	<b>28</b>
Remove Refrigerator .....	28
Replace Refrigerator .....	28

## FIGURES

Fig. 1 - Refrigerator information label location .....	4
Fig. 2 - Front view .....	5
Fig. 3 - Rear view .....	6
Fig. 4.1 - LED .....	9
Fig. 4.2 - Female connectors .....	9
Fig. 4.3 - 12 VDC .....	9
Fig. 4.4 - Adapter .....	10
Fig. 4.5 - LED .....	10
Fig. 4.6 - 12VDC .....	10
Fig. 5 - Mode Button will display Electronic Controls Fault Codes .....	24
Fig. 6 - Wiring diagram .....	27

## SAFETY

It is not possible to anticipate all of the conceivable ways or conditions under which the refrigerator may be serviced or to provide cautions as to all of the possible hazards that may result. Standard and accepted safety precautions and equipment should be used when working on electrical circuits and handling toxic or flammable materials. Safety goggles and other required protection should be used during any process that can cause material removal, such as when removing a leaking cooling unit and cleaning components.

Read this manual carefully and understand the contents before working on the refrigerator. Be aware of possible safety hazards when you see the safety alert symbol on the refrigerator and in this manual. A signal word follows the safety alert symbol and identifies the danger of the hazard. Carefully read the descriptions of these signal words to fully know their meanings. They are for your safety.



This signal word means a hazard, which if ignored, can cause small personal injury or much property damage.



This signal word means a hazard, which if ignored, can cause dangerous personal injury, death.



The storage of flammable materials behind or around the refrigerator creates a fire hazard. Do not use the area behind the refrigerator to store anything, especially flammable materials (gasoline, cleaning supplies, etc.).

A circuit overload can result in an electrical fire if the wires and/or fuses are not the correct size. Use only the wire and fuse sizes as written in the "Installation Manual."

Incorrect installation, adjustment, change to, or maintenance of this refrigerator can cause personal injury, property damage, or both. Have service and maintenance work done by your dealer or by an authorized Norcold Service Center.

Disconnect the DC power sources before doing any maintenance work on the refrigerator.



Do not bypass or change the refrigerator's electrical components or features.

Do not spray liquids near electrical outlets, connections, or the refrigerator components. Many liquids are electrically conductive and can cause a shock hazard, electrical shorts, and in some cases fire.

Do not touch the evaporator or other metal parts inside the refrigerator cabinet with wet hands because they can freeze to the refrigerator.

The rear of the refrigerator has sharp edges and corners. To prevent cuts or abrasions when working on the refrigerator, be careful and wear cut resistant gloves.

## INTRODUCTION

### About this Manual

This service manual provides maintenance, diagnostic, and repair information for **NORCOLD**® N10DCX compressor refrigerators. It is a reference tool designed for technicians who are knowledgeable in the theory and operation of AC/DC electrical systems as installed in a variety of recreational vehicles (RV).

All information, illustrations, and specifications contained in this publication are based on the latest product information available at the time of publication. **NORCOLD**® reserves the right to make changes at any time without notice.

### Certification and Code Requirements

**NORCOLD**® compressor refrigerators are certified under the latest edition of *UL 60335-1* standards.

Electrical components are  compliant.

### About Installation





Refrigerator installation must conform with the N10DCX Series *Installation Manual* for the **NORCOLD**® limited warranty to be in effect. Installation must also comply with applicable local codes and standards set by the relevant certification agency.

### Replacement Parts

Use only authorized **NORCOLD**® replacement parts. Generic parts do not meet **NORCOLD**® specifications for safety, reliability, and performance. The use of unauthorized aftermarket or generic replacement parts voids the refrigerator's limited warranty coverage.

### Technical Assistance

If unable to resolve technical issues using the information provided in this manual, technical support is available through **NORCOLD**® Customer Service Center:

	Telephone:	1-800-444-7210
	Fax:	1-734-769-2332
	email	info@thetford.com
	World Wide Web:	www.norcold.com

The following information is required to process technical support requests:

- Refrigerator Model Number
- Refrigerator Serial Number
- Recreational Vehicle (RV) Make/Model/Year

## Refrigerator Model Number

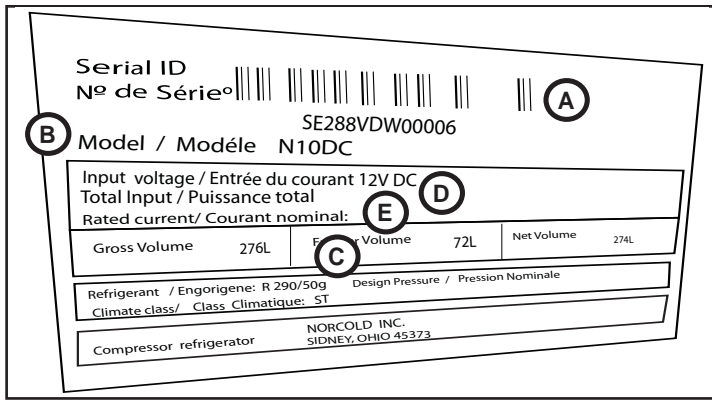

Fig. 1 - Refrigerator information label location

A	Serial Number
B	Model Number
C	Amount of refrigerant in cooling system
D	DC Voltage / Amperage

## SPECIFICATIONS

### N10DCX - Electronic

- ON/OFF, Mode, Temperature Set
- Multiple LED indicator lights
- Five (5) Temperature Settings (Separate settings for freezer and fresh food compartments)
- Night Mode

**Rough Opening Dimensions** ---- 59.88 - 60.01 high x 23.50 - 23.63 inched wide x 24.00 inches deep

### Internal Capacity

Total capacity -----9.7 cubic feet

### DC (Direct Current) Specifications

Electronic Controls DC voltage input requirement -----10.4 to 15.4 VDC

Minimum (cut-out)-----10.4 VDC

Restart (cut-in)-----11.7 VDC

### DC Fuse Requirements

DC Power Supply In-Line Fuse -----15 A

### DC Resistance / Amperage Ratings

Exterior Cooling Fan-----0.18A

Interior Fan-----.09A

Interior Light -----.13A

### Off-level Operating Limits

Side-to-side -----10 degrees maximum at refrigerator

Front-to-back -----10 degrees maximum at refrigerator

## Exploded Views

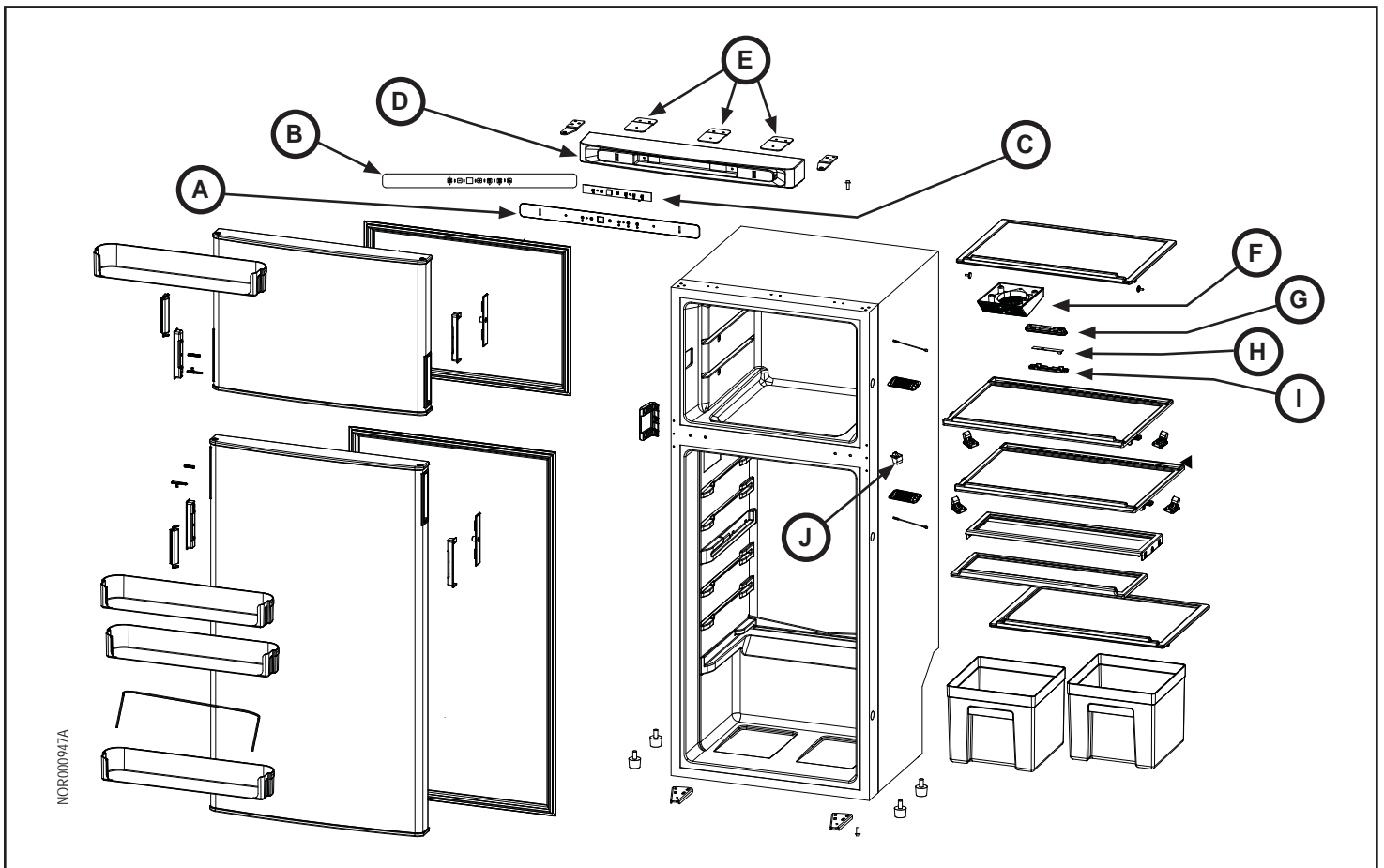
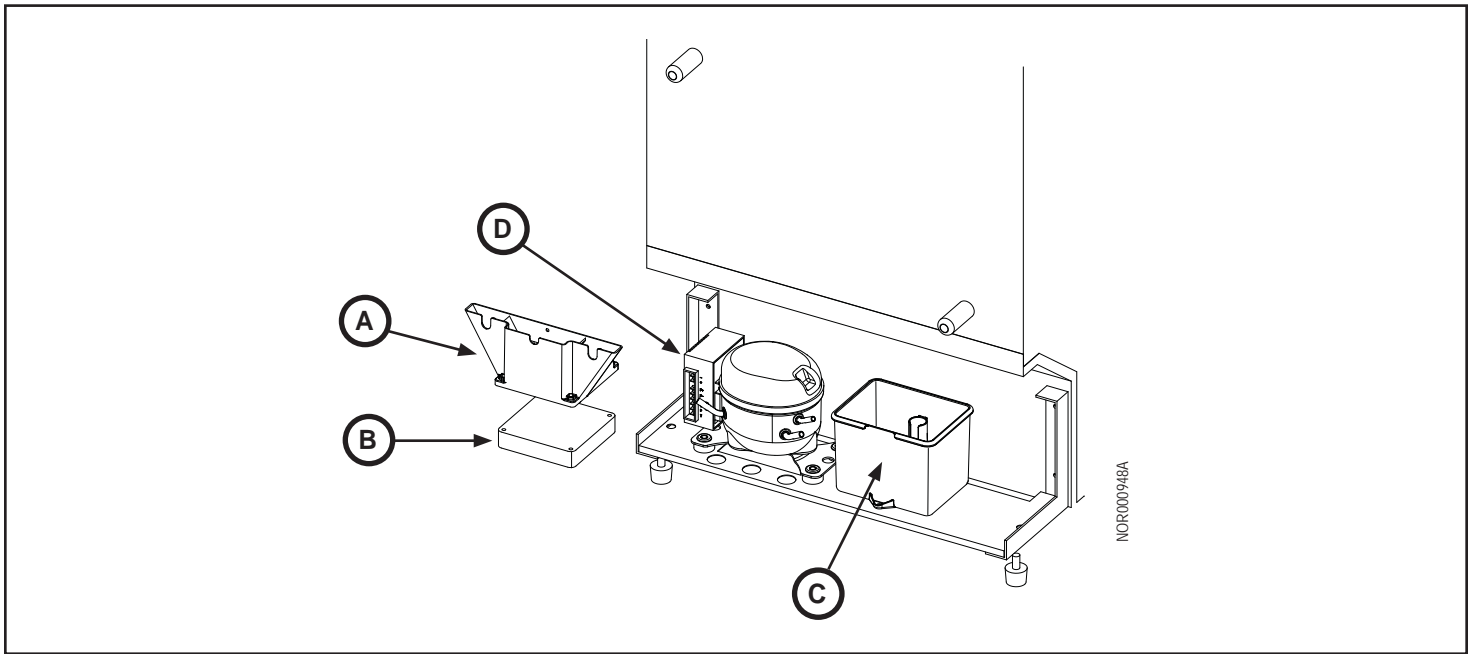

Fig. 2 - Front view

No.	Description
A	Control Panel
B	Control Panel Label
C	Control Board
D	Control Housing
E	Control Housing Bracket (3x)
F	Fan and Housing
G	Light Housing
H	Light
I	Light Cover
J	Door Light Switch



**Fig. 3 - Rear view**

No.	Description
A	Exterior Fan Vent
B	Exterior Fan
C	Drip Cup
D	Control Module

# GENERAL INFORMATION

## Installation

To confirm that installation is adequate, make sure:

- Ventilation is adequate. Refer to "Ventilation" section.
- Electrical components are installed and operating in a safe condition.
- Refrigerator is installed on a solid and level floor (not on carpet) and secured.
- The floor is able to support the weight of the refrigerator and all of its contents.

## Ventilation

### Overview

The refrigerator is made for a built-in installation. Correct ventilation is necessary for the correct operation of the refrigerator and to increase the life of the refrigerator cooling system.

Ventilation allows the natural flow of air that is necessary for good ventilation. Cooler air comes in through the lower vent, goes around the refrigerator coils where it removes the excess heat from the refrigerator components, and goes out through the upper vent / control cover. If this air flow is blocked or decreased, the refrigerator will not cool correctly. Do not install the refrigerator in a completely enclosed area such as a closet or a cabinet.

### WARNING

The refrigerator has built-in vents at the top and the bottom. Make sure that the air flow through these vents is not blocked in any way. Blockage of the air flow through these vents can:

- Shorten the life of the refrigerator cooling system.
- Cause poor cooling performance of the refrigerator.
- Cause continuous operation of the refrigerator cooling system.
- Cause fast battery discharge.
- Void the refrigerator warranty.

## 12 Volts DC Electrical Connection

To reduce the risk of electrical interference from other DC appliances and induction from voltage spikes:

- The refrigerator must have an independent 12 volt supply and not be on the same circuit as other DC appliances.
- Route the DC power supply wires, including the fuses, directly from the battery to the refrigerator.

### CAUTION

The use of a battery in parallel and between the refrigerator and any electrically filtered DC power converter or battery charger used to supply DC power to the refrigerator is recommended.

- Power converters or battery chargers used to supply DC power are examples of installations that should have parallel battery operation.
- If an electrically filtered DC power converter is used as the sole source of power, it must have a maximum DC ripple voltage of less than or equal to 250mV.

### Polarity

### CAUTION

If the DC leads are installed incorrectly, the refrigerator will not operate.

- Connect the DC (positive) supply wire from the battery to the red wire of the refrigerator.
- Connect the DC (negative) supply wire from the battery to the black wire of the refrigerator.

# DIAGNOSTICS

## Diagnostic Pre-Checks

Diagnosing problems begins by starting with the basics. In many cases, the problem can be solved by verifying the unit is operating in acceptable conditions. Before performing detailed diagnostics make sure:

- The refrigerator is turned ON.
- The door is closed and sealing correctly.
- The refrigerator is correctly installed and the vents are not blocked.
- The vehicle fuse or circuit breaker is intact.

### NOTICE

There may be more than one (1) over-current device in the refrigerator supply circuit. Be sure to check both the RV and refrigerator.

- The ambient temperature is not unusually high (more than 110° F. / 43° C.).
- The air circulation inside the refrigerator is not decreased by foods or by shelves that are covered with plastic, paper, etc.
- The freezer is defrosted.

Then do the following procedure.

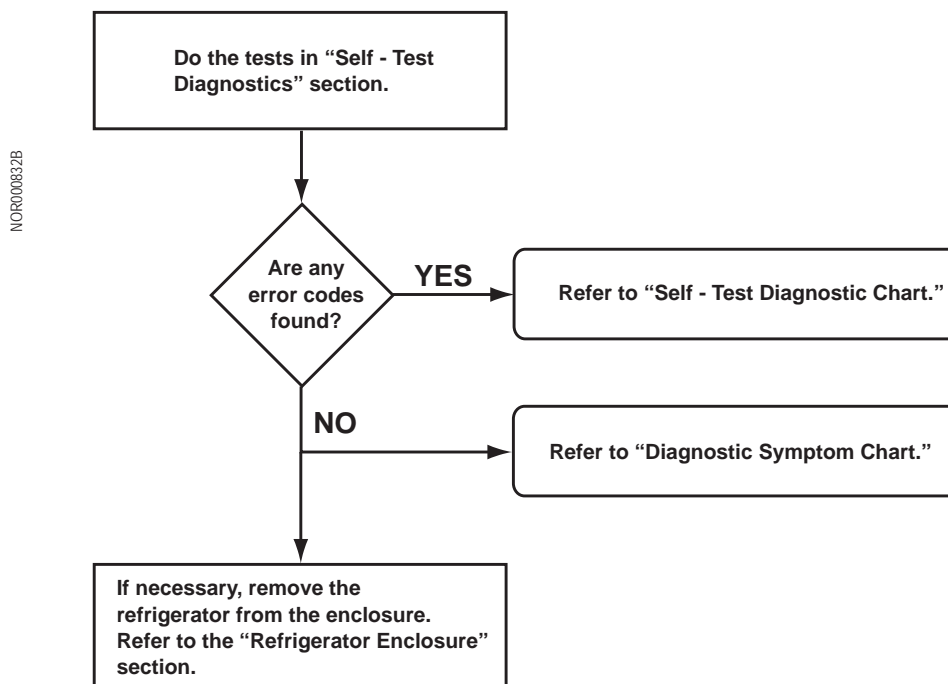



## Self-Test Diagnostics

The unit's control module is equipped with a "Self-Test Diagnostic" function which can be read using light emitting diode (LED) and terminal connectors.

### Table of LED References

References for Figs. 4.1 - 4.6

No.	Description
A	10 mA LED With Wire Leads
A1	Black LED Wire (with connector attached)
A2	Red LED Wire (with connector attached)
B	1/4 Inch Push-On Female Connector (2x)
C	1/4 Inch Adapter With One (1) Female and Two (2) Male Connections
D	12 VDC Input Wire
E	Positive (+) Terminal "+" of Control Module
F	Terminal "D" of Control Module
G	Control Module

### Conducting the LED Evaluation

Follow the steps below. If an error code is activated in the control module (Fig. 4.3, G) and the LED (Fig. 4.1, A) is connected, it will flash a number of times. The number of flashes will depend on what error was recorded. Each flash will last 1/4 second and after the code is flashed there will be a delay, then the code will repeat.

Write down all error codes; then refer to "Self-Test Diagnostic Chart" in this section.

### Prepare to Connect the LED

You will need the following to conduct self-diagnostics:

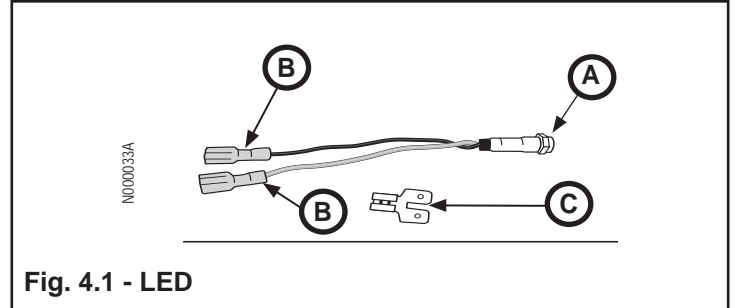

Fig. 4.1 - LED

- A 10 mA LED with wire leads (See Fig. 4.1, A).
- Two (2) 1/4 inch push-on female connectors (See Fig. 4.1, B).
- A 1/4 inch adapter with 1 female to 2 male connections. (See Fig. 4.1, C)

**NOTICE**

Do not leave jumpers in place for normal operation.

### Connect the LED

Refer to Figs. 4.2- through 4.6

#### Step 1. Attach Female Connectors.

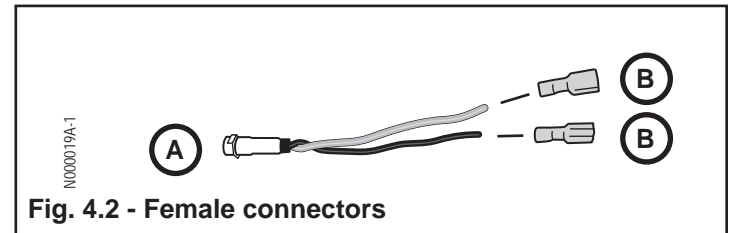

Fig. 4.2 - Female connectors

Attach a female connector to each LED wire lead.

#### Step 2. Disconnect 12 VDC

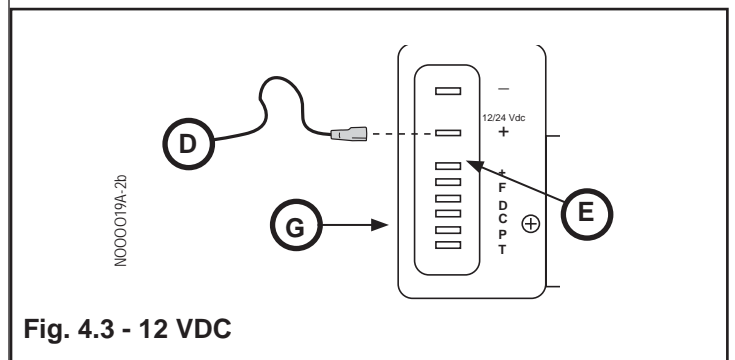
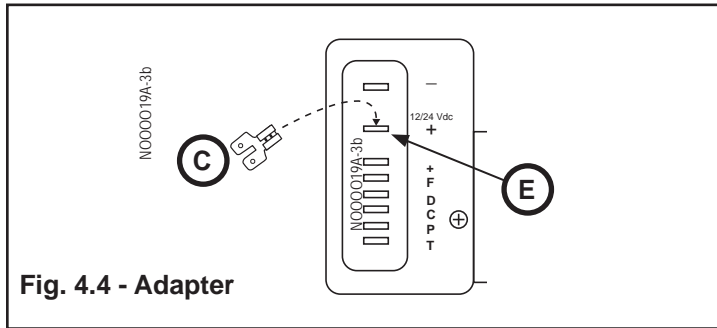

Fig. 4.3 - 12 VDC

Disconnect the 12 VDC input wire from the positive terminal of the control module.

**Step 3. Connect Adapter**



Connect the adapter to the positive terminal of the control module.

**Step 4. Connect LED**

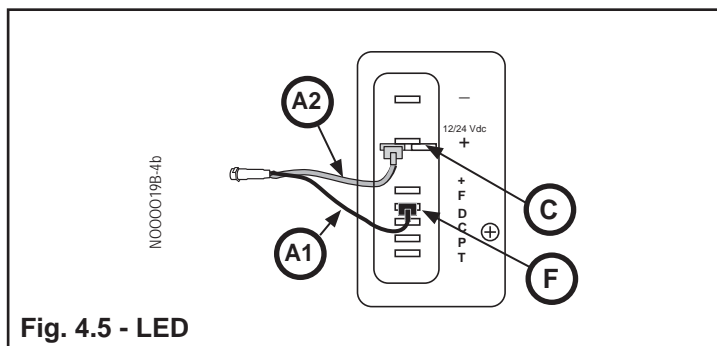

Connect the black LED wire to one side of the adapter; connect the red LED wire to terminal "D" of the control module.

**Step 5. Connect 12VDC**

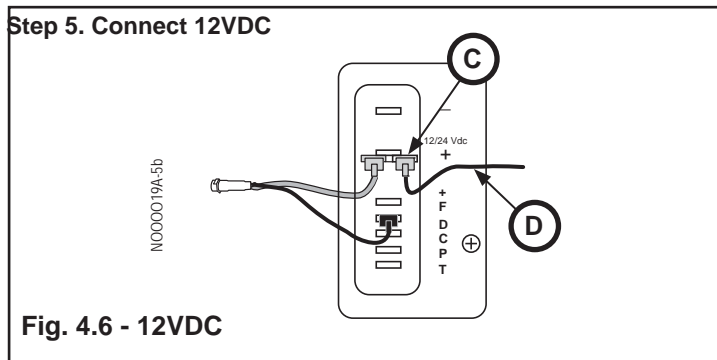

Connect the 12 VDC input wire to the other side of the adapter.

**NOTICE** Do NOT leave jumpers in place for normal operation.

**Self-Test Diagnostic Chart**

Flashes	Description	Action
1	<b>Battery Protection Cut-Out.</b> The voltage is outside the cut out setting.	Perform Test A.
2	<b>Fan Over current Cut-Out.</b> The fan electrical load is more than 1.0 amp.	Perform Test B.
3	<b>Motor Start Error.</b> The rotor is blocked or the differential pressure in the refrigeration system is too high (>5 bar).	Perform Test C.
4	<b>Minimum Motor Speed Error.</b> The motor can not maintain minimum speed (1850 rpm).	Perform Test D.
5	<b>Thermal Cutout of Electronic Unit.</b> The electronic unit is running too hot.	Perform Test E.
6	Controller Hardware Failure Controller detects abnormal parameters	Perform Test K.

**Diagnostic Symptom Chart**

Problem	Possible Cause	Action to Take
Not cooling, not turning on.	- Faulty thermistor. - No power to control module. - Faulty wire from control module to compressor - Faulty control module. - Faulty Compressor.	Perform Test F.
Refrigerator gets too cold.	- Bad capillary tube position. - Faulty thermistor - Faulty control module.	Perform Test G.
Refrigerator builds frost inside.	- Door not closed. - Damaged door gasket.	Perform Test H.
Runs, but does not cool properly.	- High ambient temperatures . - Blocked air ventilation. - Frost build up. - Condenser coil restricted. - Faulty condenser fan. - Faulty cooling unit.	Perform Test I.
Will not run on DC power.	- Blown fuse in DC circuit. - Undersized wiring to refrigerator, minimum #12 gauge wire required. - Refer to Owner's Manual for recommended wire size. - Partially discharged battery, voltage below 11.3 VDC at compressor module. - High resistance (voltage drop) in supply circuit.	Perform Test J.
Voltage within range; refrigerator cuts out.	- Parts can cause a +/- 10 VDC which can cause refrigerator voltage to register within specification, but cutout because of part variance.	Perform Test K.

**Electronic Controls Fault Code Chart**

Fault Code	Fault Code Meaning	Action to Take
E1	The thermistor in the fresh food compartment is not cycling properly.	Refer to "Fault Code - "E1"" on page 24.
E2	The thermistor in the freezer compartment is not cycling properly.	Refer to "Fault Code - "E2"" on page 25.
E3	The voltage is outside the cut out setting.	Refer to "Fault Code - "E3"" on page 26.
E4	The fresh food compartment door has been open for more than two (2) minutes.	Refer to "Fault Code - "E4"" on page 26.

# TROUBLESHOOTING

## Troubleshoot Compressor Control Module

### Test A, Battery Protection Cut-Out

Before starting this procedure make sure the DC supply voltage to the refrigerator is correct. The DC supply voltage must be:

- More than 11.7 VDC to start.
- Remain between 10.4 VDC to 15.4 VDC to continue operation.

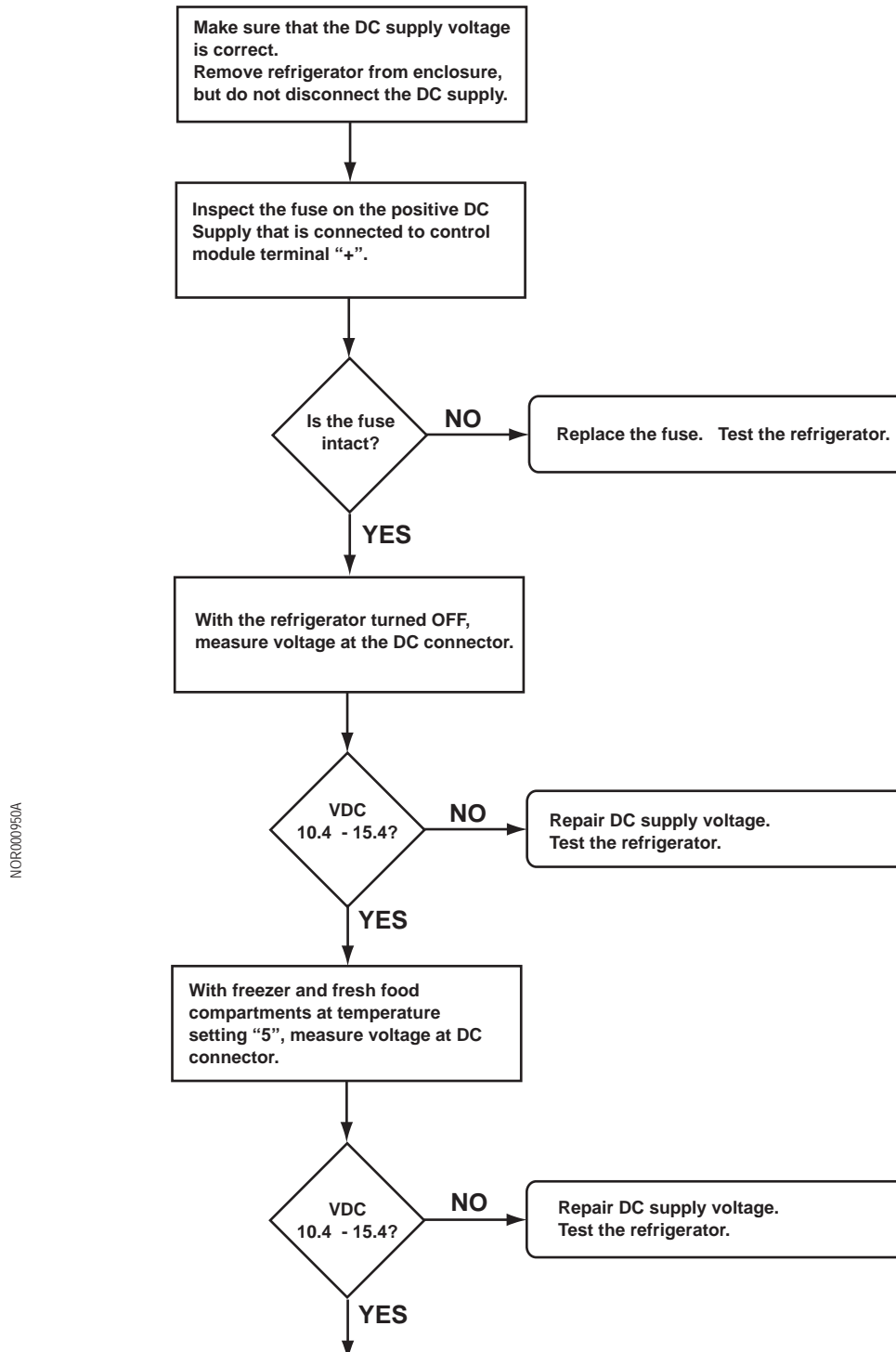

Continued on next page.

Continued from previous page.

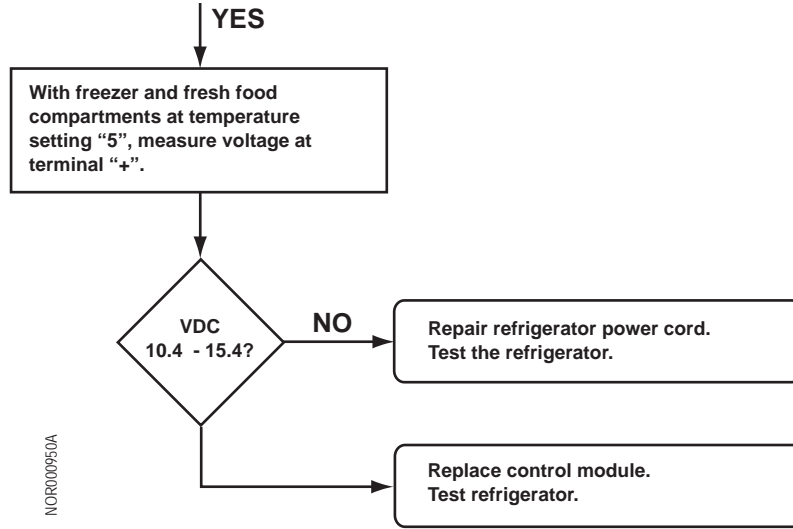

### Test B, Fan Over Current Cut-Out

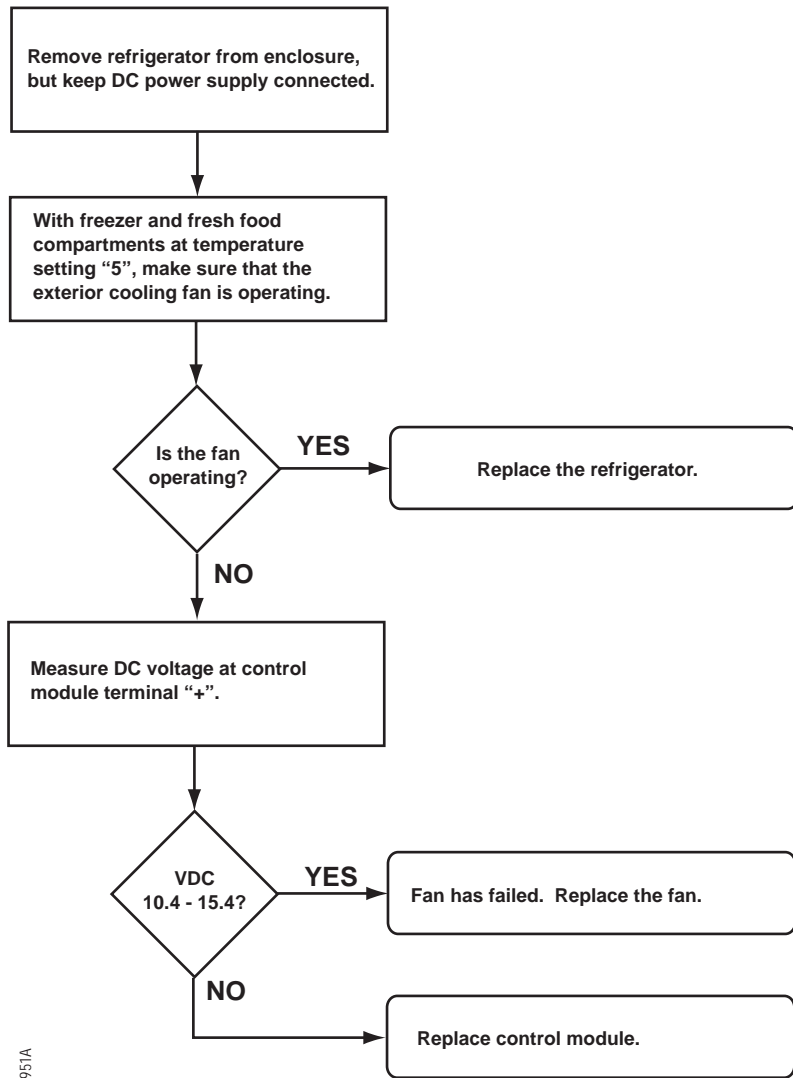

NOR000951A

### Test C, Motor Start Error

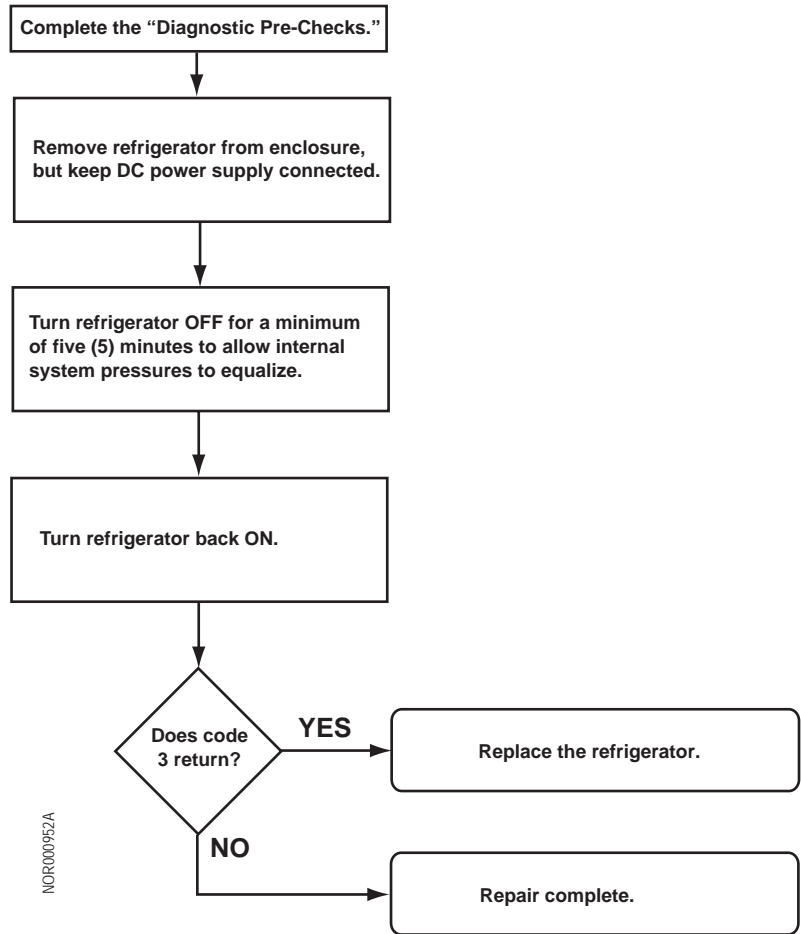

### Test D, Minimum Motor Speed Error

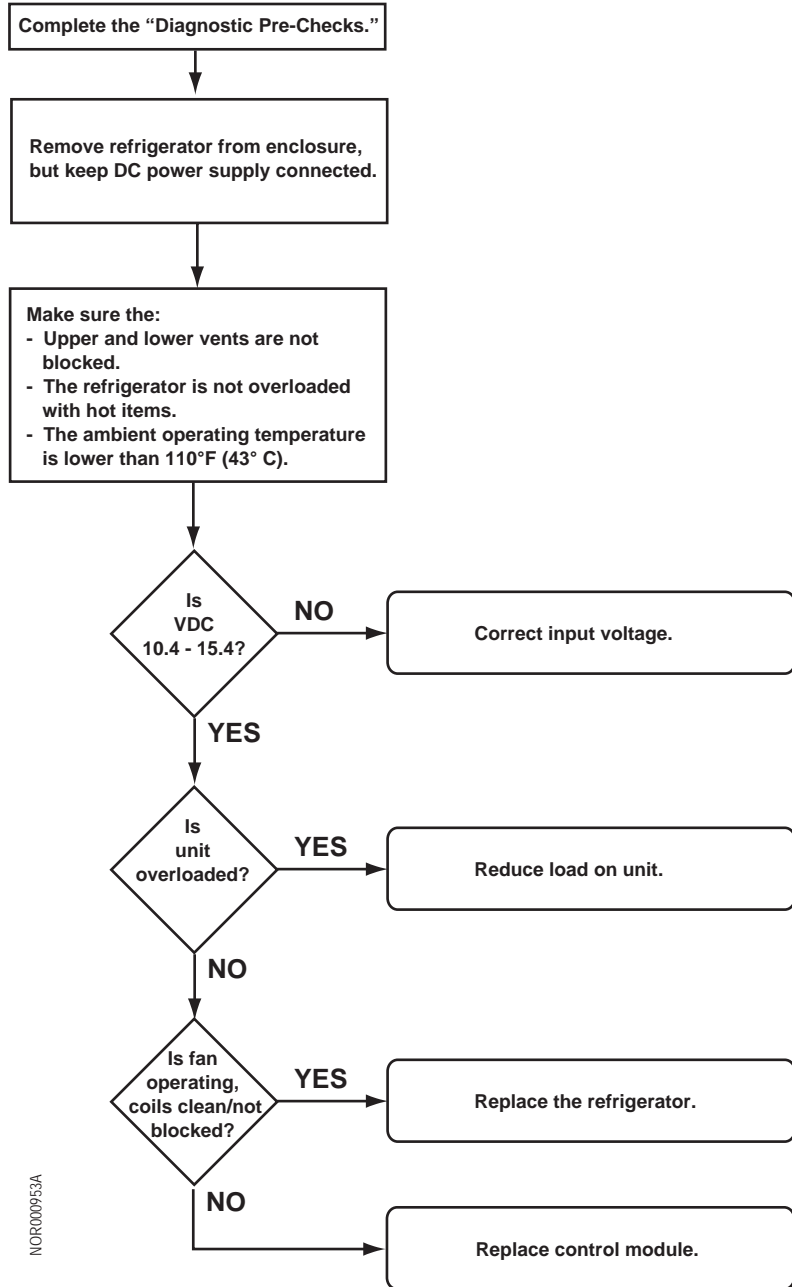

NOR000953A

### Test E, Thermal Cut-Out of Electronic Unit

## NOTICE

The control module has a built in thermal protection which stops the compressor operation if the control module circuit board temperature is higher than 203° F (95° C). The refrigerator will not restart until the control module circuit board temperature is lower than 185° F (85° C).

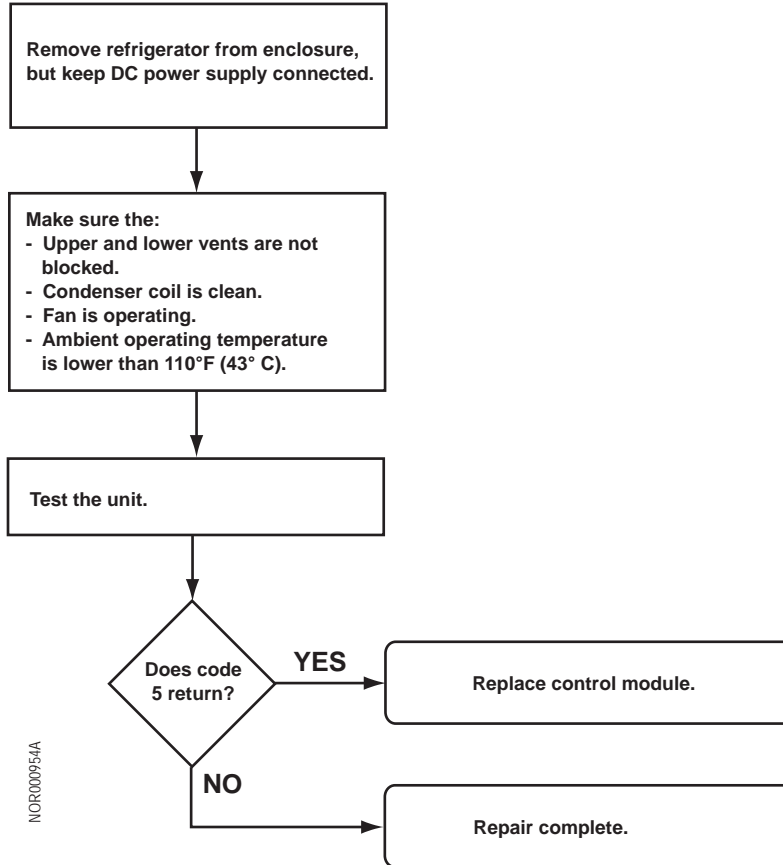



## Troubleshoot Symptoms

### Test F, Not Cooling, Not Turning On

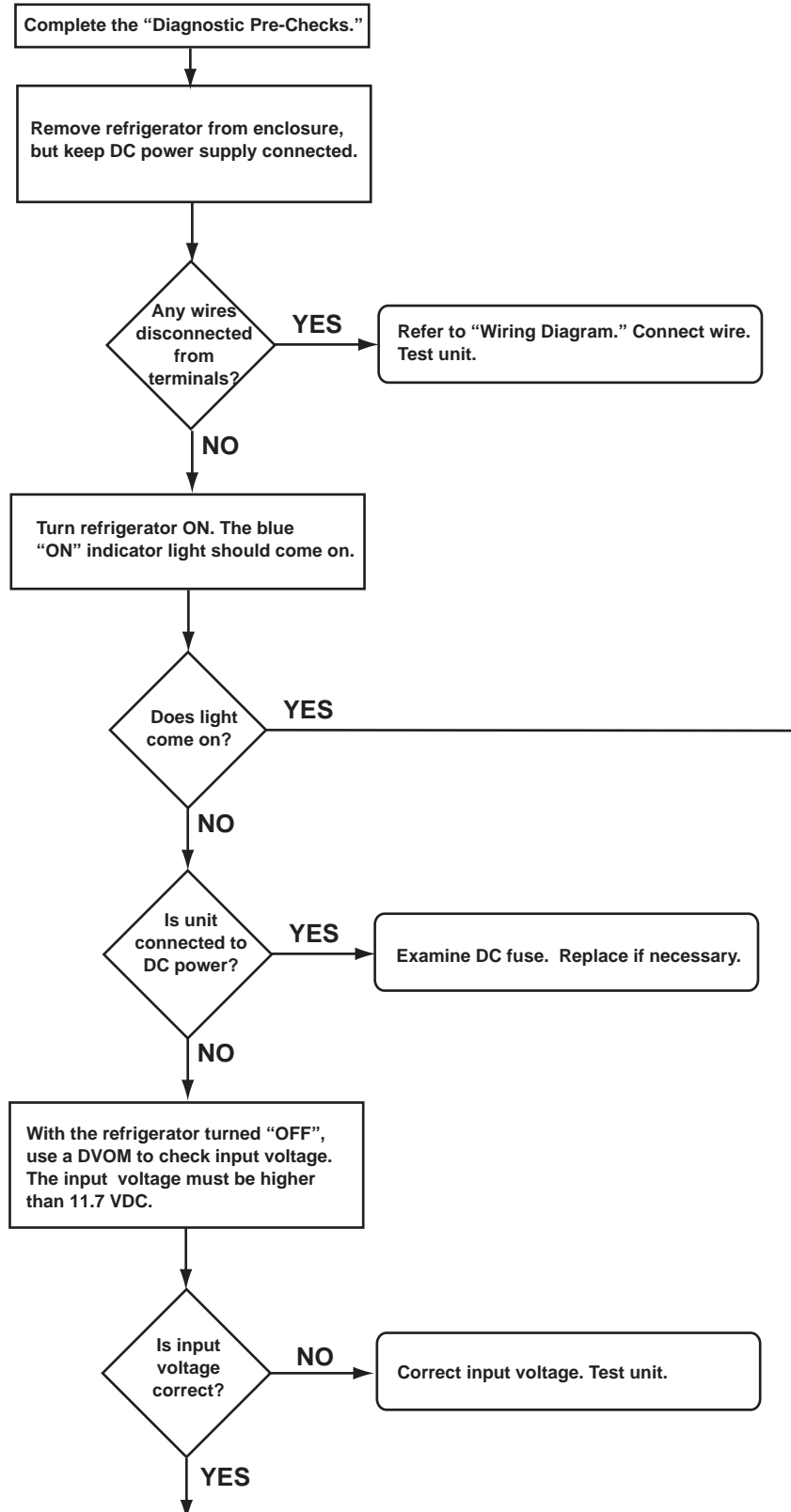

NOR000955A

Continued on next page.

Continued from previous page.

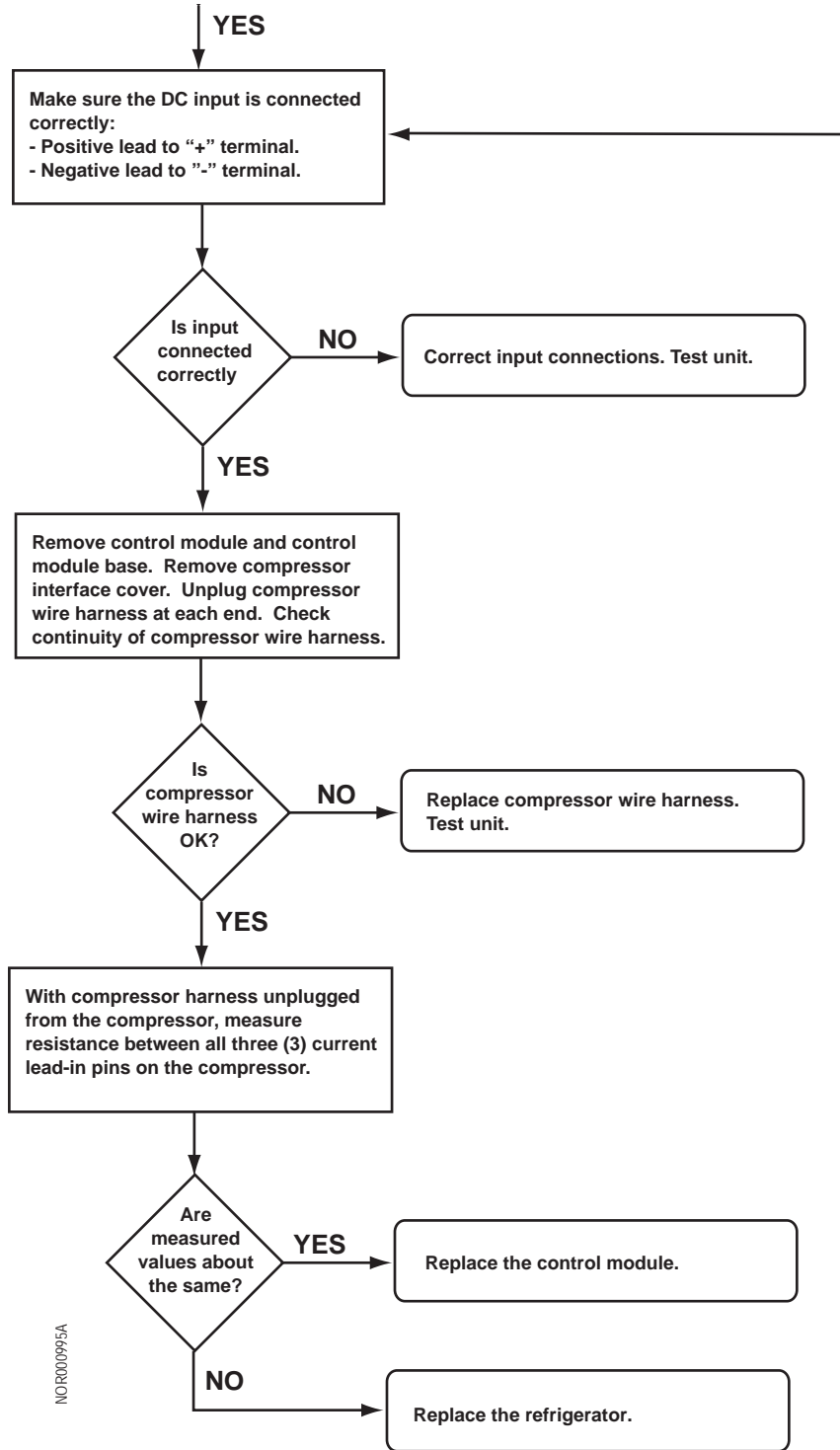

NOR000995A

### Test G, Refrigerator Gets Too Cold

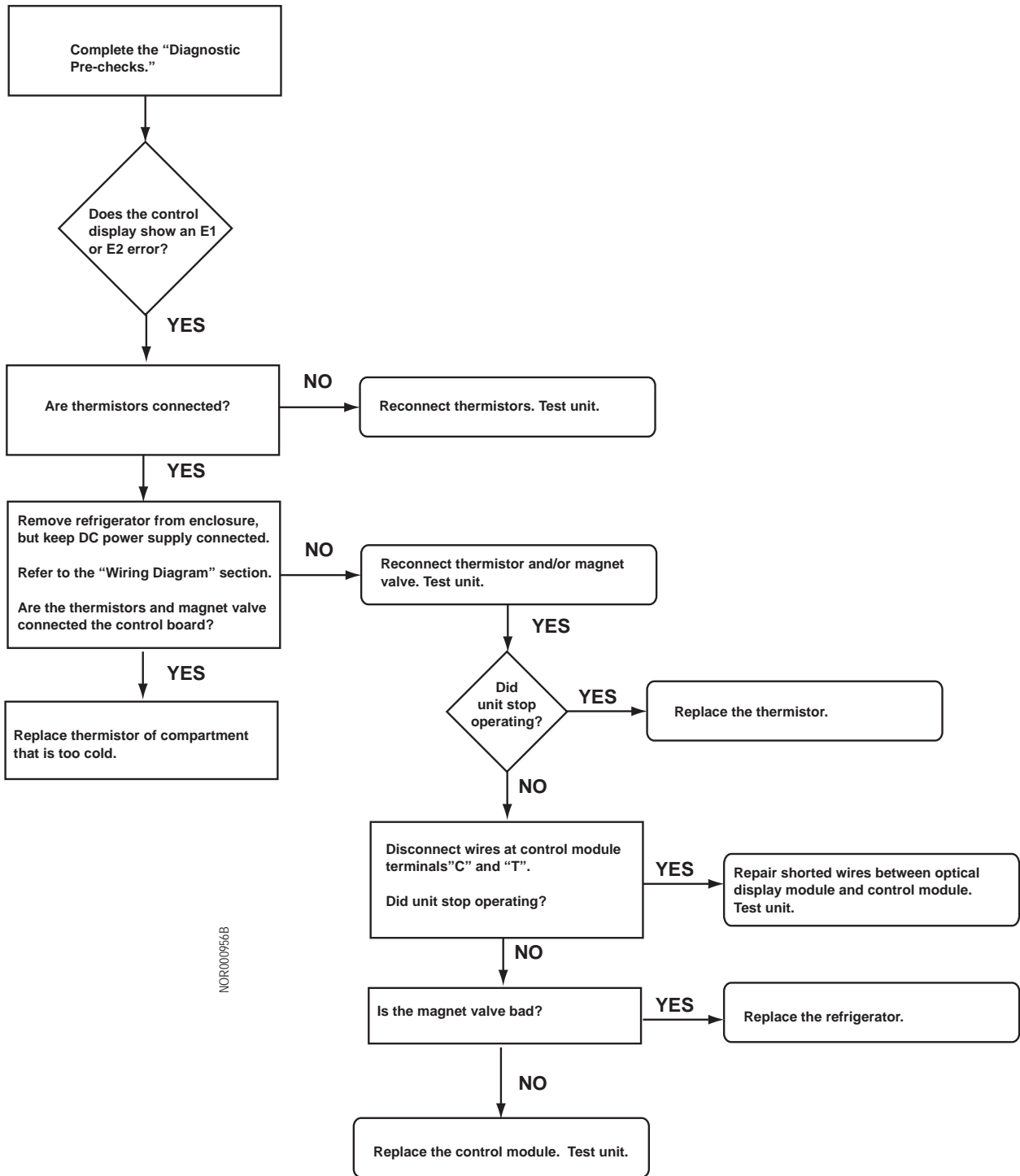

## Test H, Refrigerator Builds Frost Inside

### **NOTICE**

These models are not frost free units and the unit will have to be defrosted at times. If the unit seems to have an excessive amount of frost or it is building quickly perform the following tests.

NOR000957B

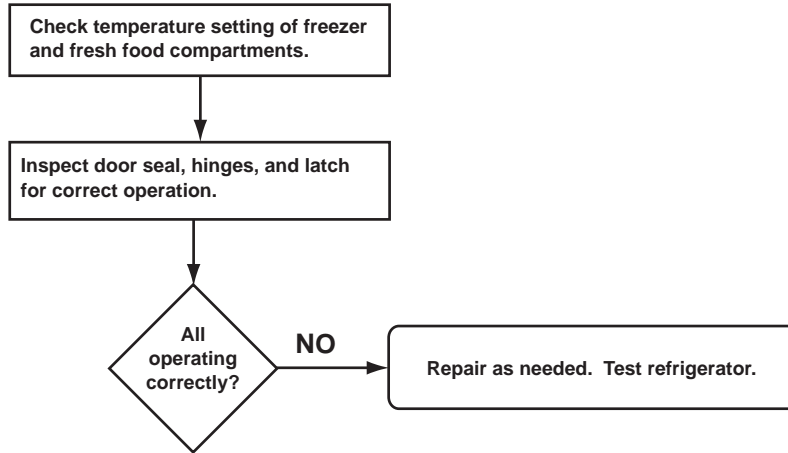

### Test I, Runs But Does Not Cool Properly

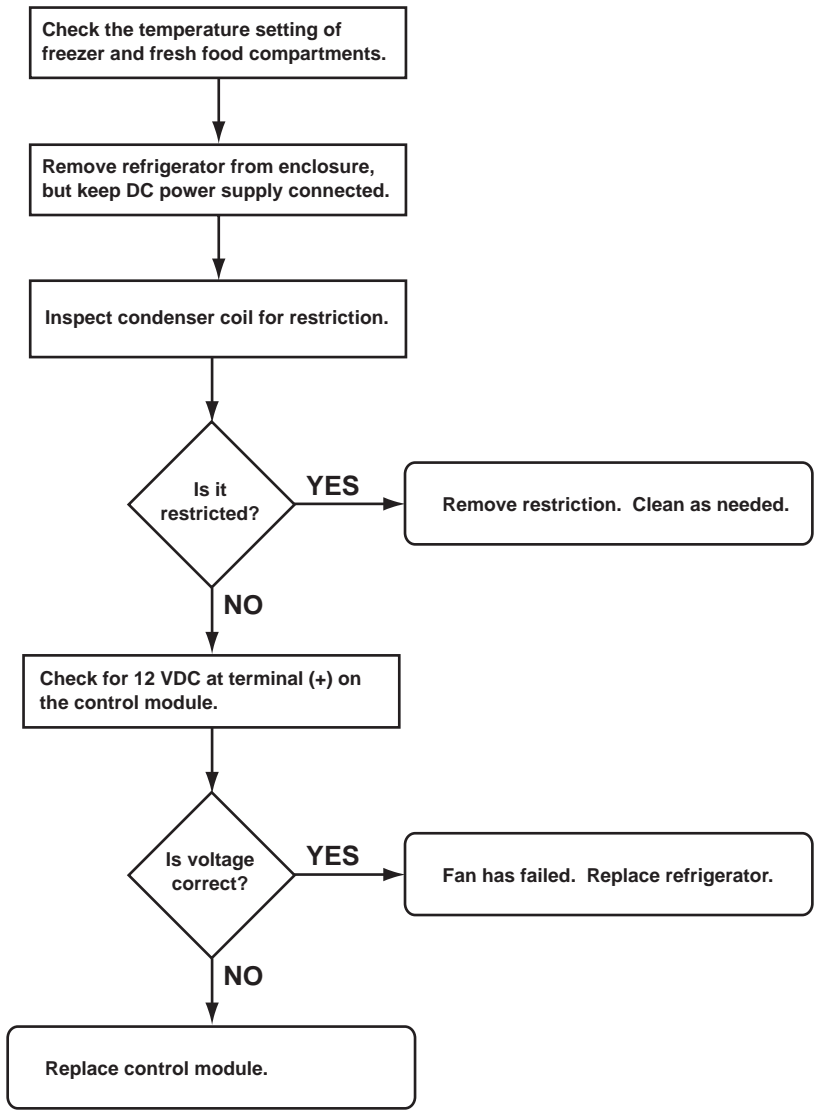

NORC00958B

### Test J, Will Not Run On DC Power

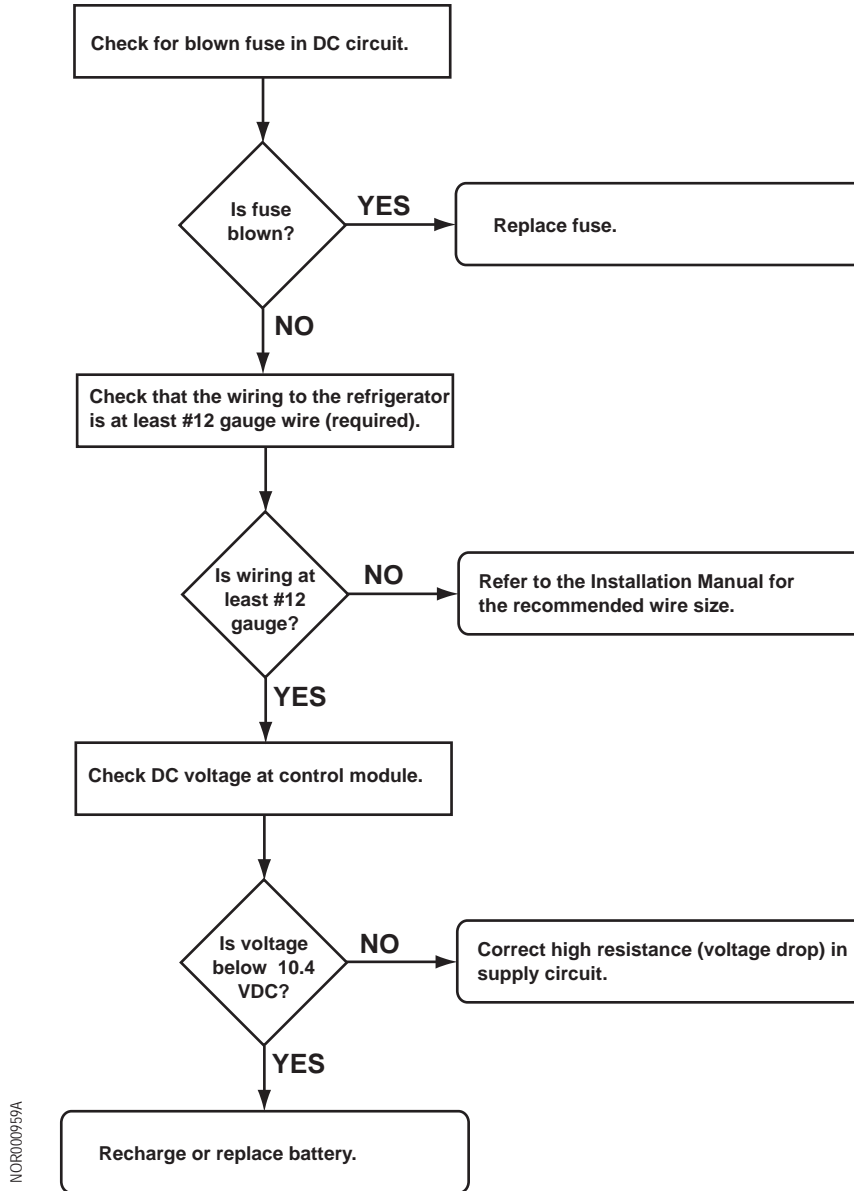

### Test K, Voltage Within Cutout Range but Refrigerator Cuts Out

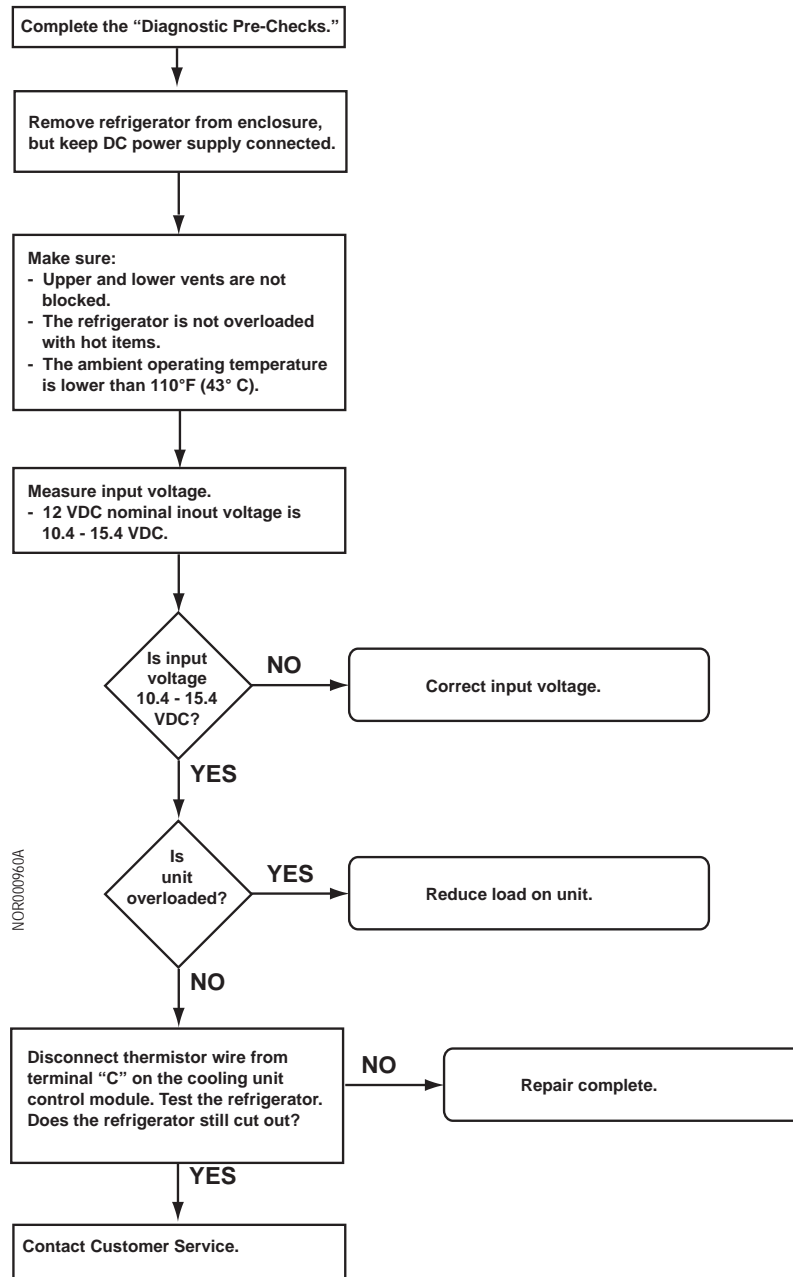

## Troubleshoot Electronic Controls Fault Codes



Fig. 5 - Mode Button will display Electronic Controls Fault Codes

### Fault Code - "E1"

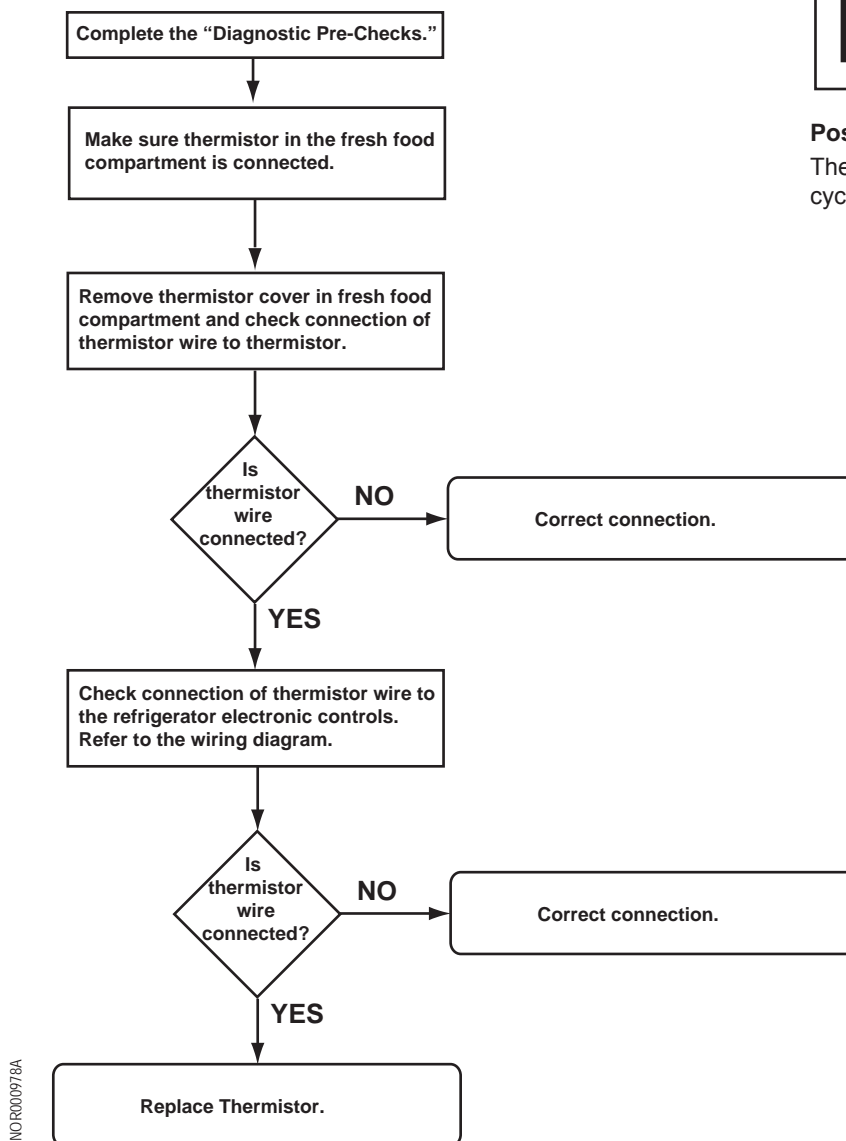

**E1**

**Possible Cause:**  
The fresh food thermistor is not cycling properly.



## Fault Code - "E2"

**E2**

**Possible Cause:**  
The freezer thermistor is not cycling properly.

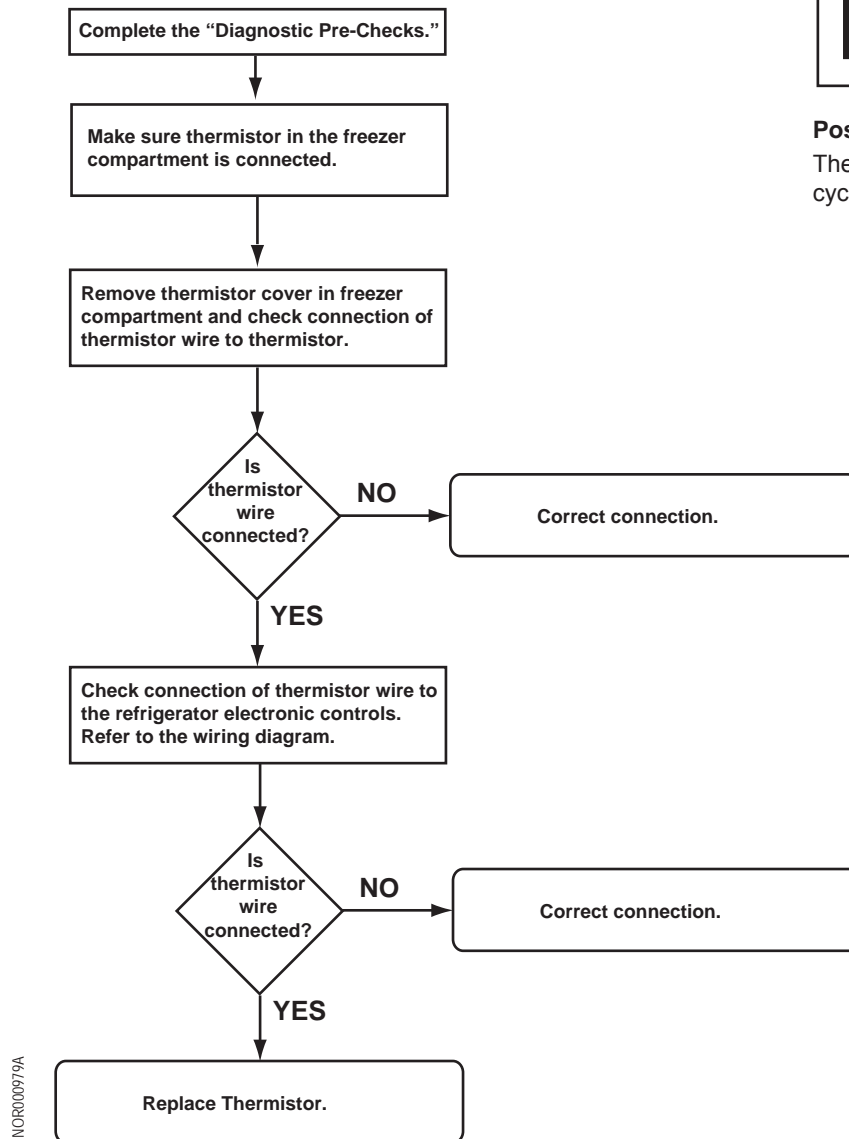

## **Fault Code - "E3"**

---

Correct the DC input voltage to the refrigerator. Make sure the input voltage is 12.0 VDC.

**E3**

**Possible Cause:**

The voltage is outside the cut-out setting.

## **Fault Code - "E4"**

---

Make sure:

- the light switch closes when the door closes.
- all of the connections to the refrigerator electronic controls are intact.

**E4**

**Possible Cause:**

The door has been open for more than two (2) minutes.

# WIRING DIAGRAM

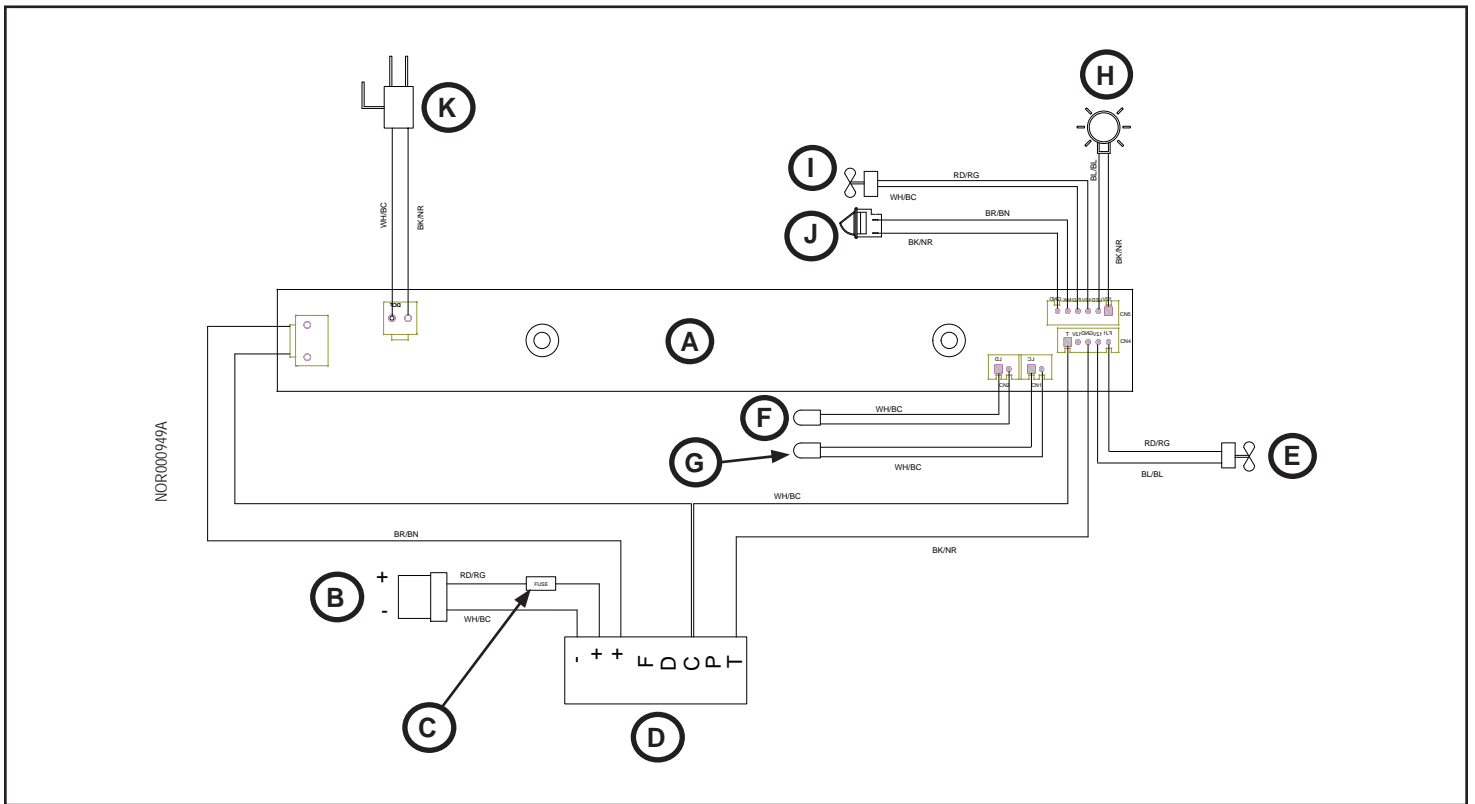

Fig. 6 - Wiring diagram

Item	Description
A	Display Module
B	12 VDC Input
C	15A Fuse
D	Main PCBA Cooling Unit
E	Exterior Fan
F	Freezer Compartment Thermistor
G	Fresh Food Compartment Thermistor
H	Interior Light
I	Interior Fan
J	Interior Light Switch
K	Magnet Valve

# REFRIGERATOR ENCLOSURE

---

## Remove Refrigerator

---

1. Disconnect all power supplies to the refrigerator.



Failure to disconnect the electrical sources can cause dangerous personal injury or death.

2. Remove the mounting screws from each mounting bracket. Pull the refrigerator forward.

## Replace Refrigerator

---

1. Push refrigerator fully into enclosure. Install screw into each mounting bracket.
2. Connect all power supplies to the refrigerator.